

JVC

SCHEMATIC DIAGRAMS

COLOR TELEVISION

AV-20D202/S

BASIC CHASSIS
FD

CD-ROM No.SML200104

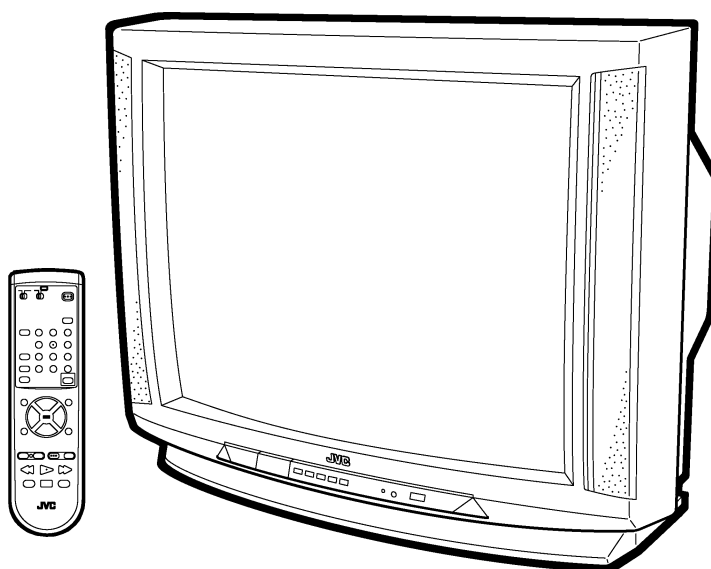

CONTENTS

■ NOTE ON USING CIRCUIT DIAGRAMS	2-1
■ SEMICONDUCTOR SHAPES	2-2
■ BLOCK DIAGRAM	2-3
■ CIRCUIT DIAGRAMS	2-5
■ PATTERN DIAGRAMS	2-10
■ CHANNEL CHART	2-13

CONTENTS

SEMICONDUCTOR SHAPES 2-2

BLOCK DIAGRAM 2-3

CIRCUIT DIAGRAMS

MAIN PWB CIRCUIT DIAGRAM 2-5

MAIN PWB, CRT SOCKET PWB CIRCUIT DIAGRAM 2-7

POWER PWB CIRCUIT DIAGRAM 2-9

PATTERN DIAGRAMS

POWER PWB PATTERN 2-10

MAIN PWB, CRT SOCKET PWB PATTERN 2-11

CHANNEL CHART (US) 2-13

CHANNEL CHART (CA) 2-14

SEMICONDUCTOR SHAPES

TRANSISTOR

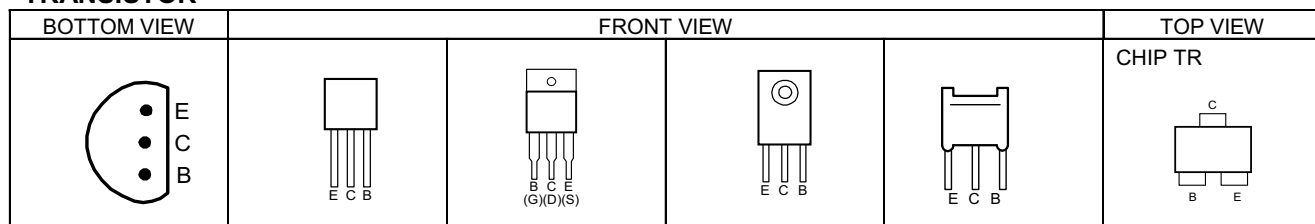

IC

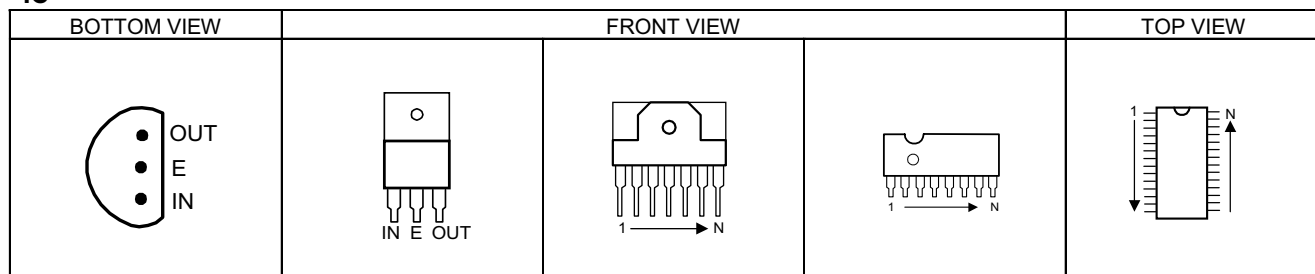

CHIP IC

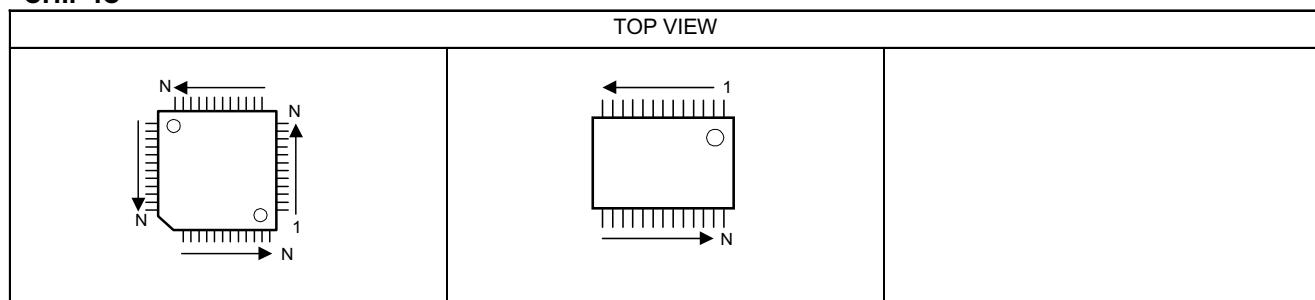

STANDARD CIRCUIT DIAGRAM

NOTE ON USING CIRCUIT DIAGRAMS

1. SAFETY

The components identified by the Δ symbol and shading are critical for safety. For continued safety replace safety critical components only with manufactures recommended parts.

2. SPECIFIED VOLTAGE AND WAVEFORM VALUES

The voltage and waveform values have been measured under the following conditions.

- (1) Input signal : Color bar signal
 - (2) Setting positions of each knob/button and variable resistor : Original setting position when shipped
 - (3) Internal resistance of tester : DC 20k Ω /V
 - (4) Oscilloscope sweeping time : H \Rightarrow 20 μ S/div
: V \Rightarrow 5mS/div
: Others \Rightarrow Sweeping time is specified
 - (5) Voltage values : All DC voltage values
- * Since the voltage values of signal circuit vary to some extent according to adjustments, use them as reference values.

3. INDICATION OF PARTS SYMBOL [EXAMPLE]

● In the PW board : R1209 \rightarrow R209

4. INDICATIONS ON THE CIRCUIT DIAGRAM

(1) Resistors

● Resistance value

- No unit : [Ω]
- K : [K Ω]
- M : [M Ω]

● Rated allowable power

- No indication : 1/16[W]
- Others : As specified

● Type

- No indication : Carbon resistor
- OMR : Oxide metal film resistor
- MFR : Metal film resistor
- MPR : Metal plate resistor
- UNFR : Uninflammable resistor
- FR : Fusible resistor

* Composition resistor 1/2 [W] is specified as 1/2S or Comp.

(2) Capacitors

● Capacitance value

- 1 or higher : [pF]
- less than 1 : [μ F]

● Withstand voltage

- No indication : DC50[V]
- AC indicated : AC withstand voltage [V]
- Others : DC withstand voltage [V]

* Electrolytic Capacitors

47/50[Example]:Capacitance value [μ F]/withstand voltage[V]

● Type

- No indication : Ceramic capacitor
- MY : Mylar capacitor
- MM : Metalized mylar capacitor
- PP : Polypropylene capacitor
- MPP : Metalized polypropylene capacitor
- MF : Metalized film capacitor
- TF : Thin film capacitor
- BP : Bipolar electrolytic capacitor
- TAN : Tantalum capacitor

(3) Coils

- No unit : [μ H]
- Others : As specified

(4) Power Supply

- : B1
- : 9V
- : 5V

*Respective voltage values are indicated

(5) Test point

- : Test point
- : Only test point display

(6) Connecting method

- : Connector
- : Wrapping or soldering
- : Receptacle

(7) Ground symbol

- : LIVE side ground
- : ISOLATED(NEUTRAL) side ground
- : EARTH ground
- : DIGITAL ground

5. NOTE FOR REPAIRING SERVICE

This model's power circuit is partly different in the GND. The difference of the GND is shown by the LIVE : (\perp) side GND and the ISOLATED(NEUTRAL) : (⏏) side GND. Therefore, care must be taken for the following points.

- (1) Do not touch the LIVE side GND or the LIVE side GND and the ISOLATED(NEUTRAL) side GND simultaneously. If the above caution is not respected, an electric shock may be caused. Therefore, make sure that the power cord is surely removed from the receptacle when, for example, the chassis is pulled out.
- (2) Do not short between the LIVE side GND and ISOLATED(NEUTRAL) side GND or never measure with a measuring apparatus (oscilloscope, etc.) the LIVE side GND and ISOLATED(NEUTRAL) side GND at the same time. If the above precaution is not respected , a fuse or any parts will be broken.

◇ Since the circuit diagram is a standard one, the circuit and circuit constants may be subject to change for improvement without any notice.

BLOCK DIAGRAM

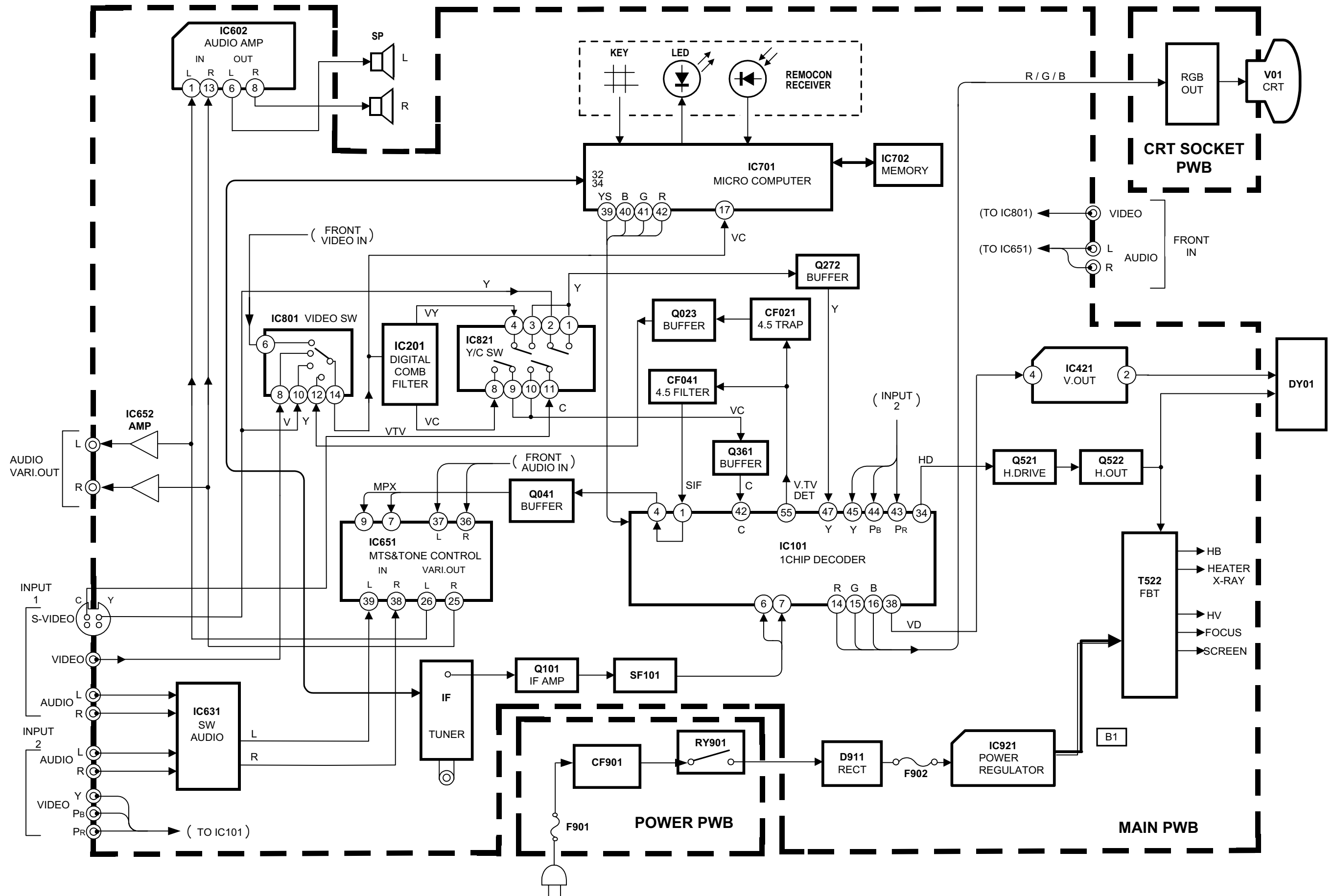

MAIN PWB, CRT SOCKET PWB CIRCUIT DIAGRAM

NOTE

●For the parts marked “ * ” in the circuit diagram, refer to the parts list.

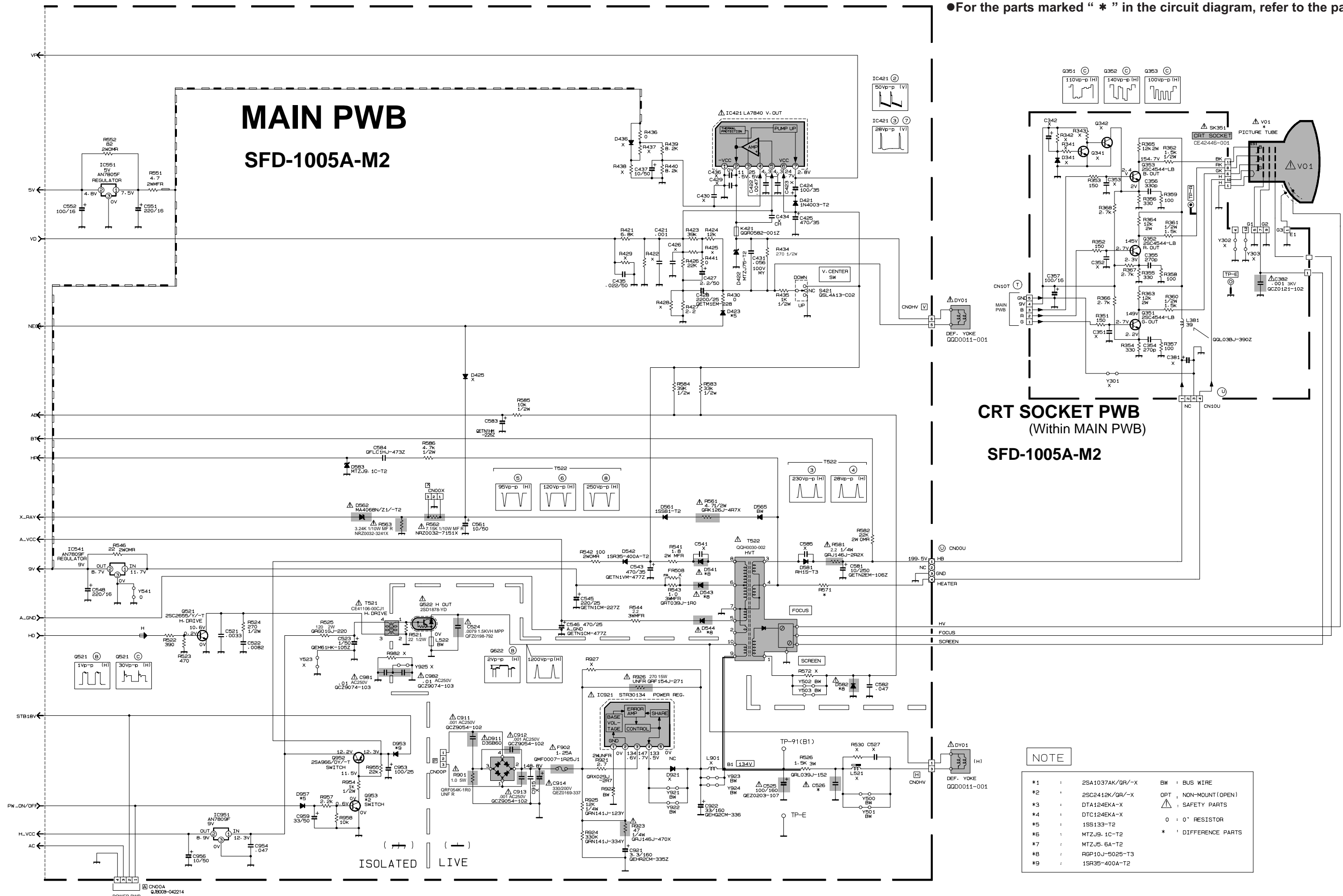

CRT SOCKET PWB
(Within MAIN PWB)
SFD-1005A-M2

NOTE

- *1 : 2SA1037AK/GR/-X BW : BUS WIRE
- *2 : 2SC2412K/GR/-X OPT : NON-MOUNT (OPEN)
- *3 : DTA124EKA-X Δ : SAFETY PARTS
- *4 : DTC124EKA-X 0 : 0^Ω RESISTOR
- *5 : 1SS133-T2 * : DIFFERENCE PARTS
- *6 : MTZJ5. 1C-T2
- *7 : MTZJ5. 6A-T2
- *8 : RGP10J-5025-T3
- *9 : 1SR35-400A-T2

POWER PWB CIRCUIT DIAGRAM

NOTE

●For the parts marked “ * ” in the circuit diagram, refer to the parts list.

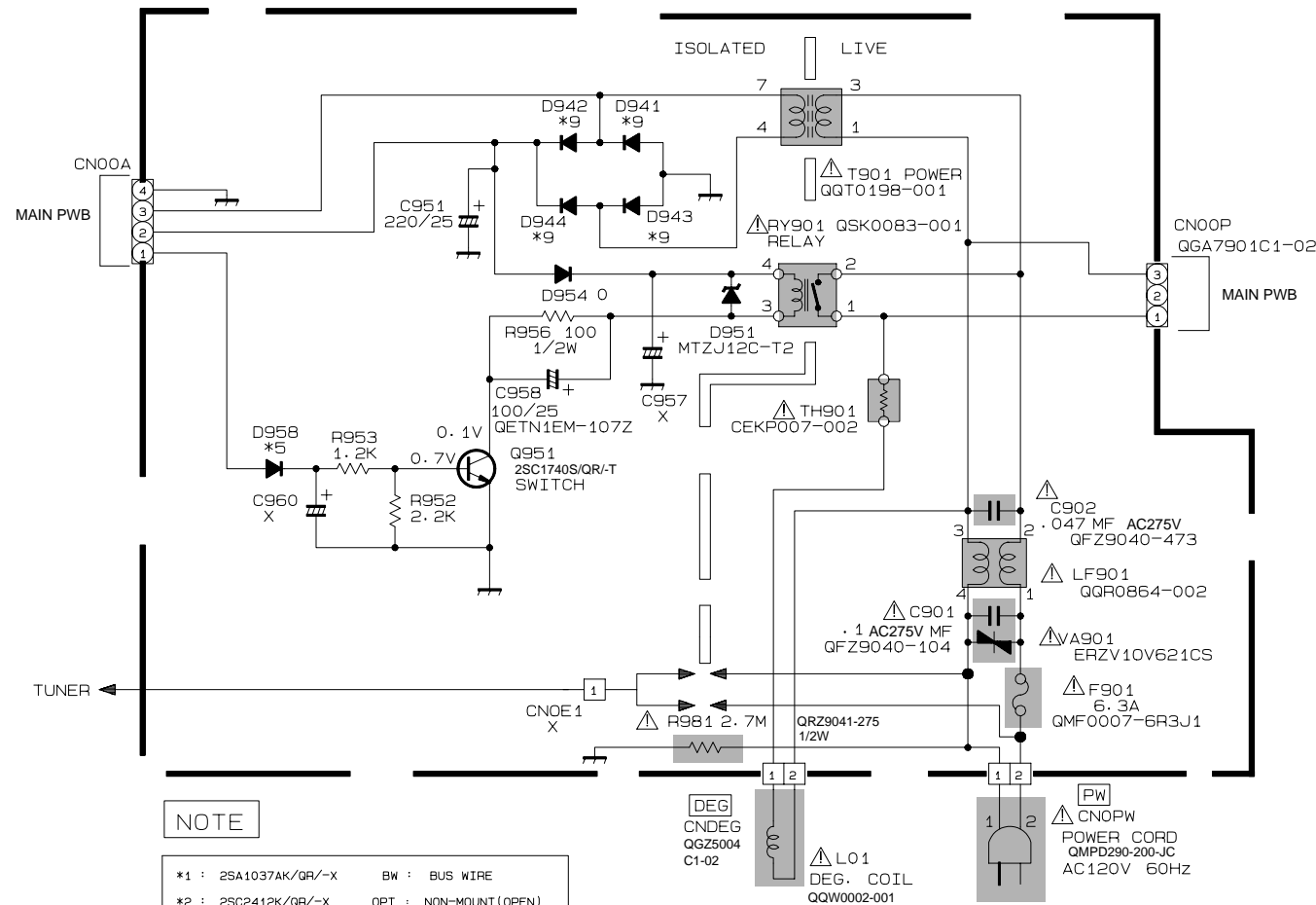

NOTE

- | | |
|----------------------|------------------------------|
| *1 : 2SA1037AK/QR/-X | BW : BUS WIRE |
| *2 : 2SC2412K/QR/-X | OPT : NON-MOUNT (OPEN) |
| *3 : DTA124EKA-X | △ : SAFETY PARTS |
| *4 : DTC124EKA-X | 0 : 0 th RESISTOR |
| *5 : 1SS133-T2 | * : DIFFERENCE PARTS |
| *6 : MTZJ9.1C-T2 | |
| *7 : MTZJ5.6A-T2 | |
| *8 : RGP10J-5025-T3 | |
| *9 : 1SR35-400A-T2 | |

**POWER PWB
SFD-9002A-M2**

PATTERN DIAGRAMS

POWER PWB PATTERN

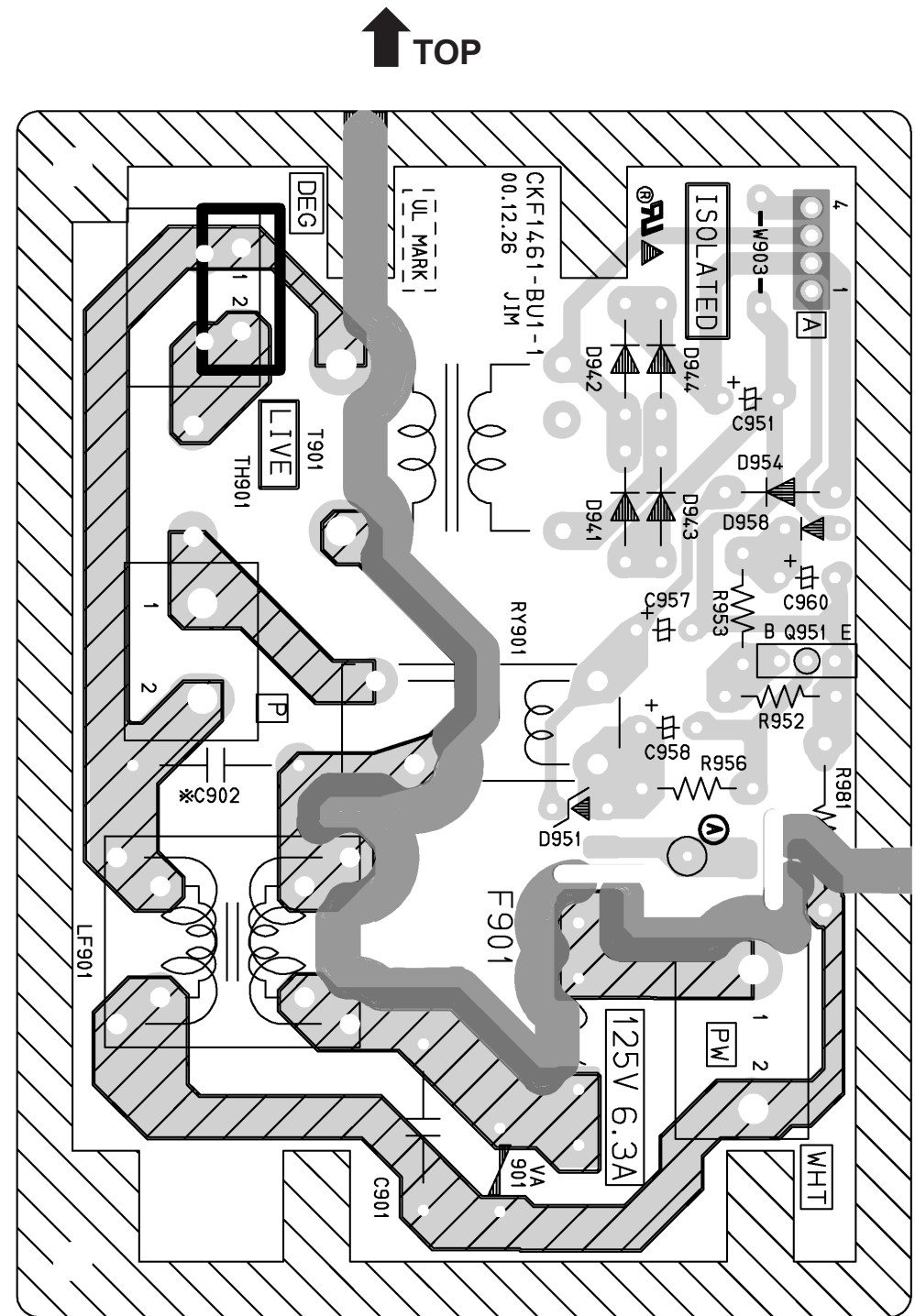

MAIN PWB, CRT SOCKET PWB PATTERN



CAUTION : FOR CONTINUED PROTECTION AGAINST FIRE HAZARD, REPLACE ONLY WITH SAME TYPE AND RATED FUSE(S) AND ROHM'S MFR'D TYPE CP(S): OR EQUIVALENT

CRT SOCKET PWB ASS'Y

FRONT

MAIN PWB ASS'Y

TOP

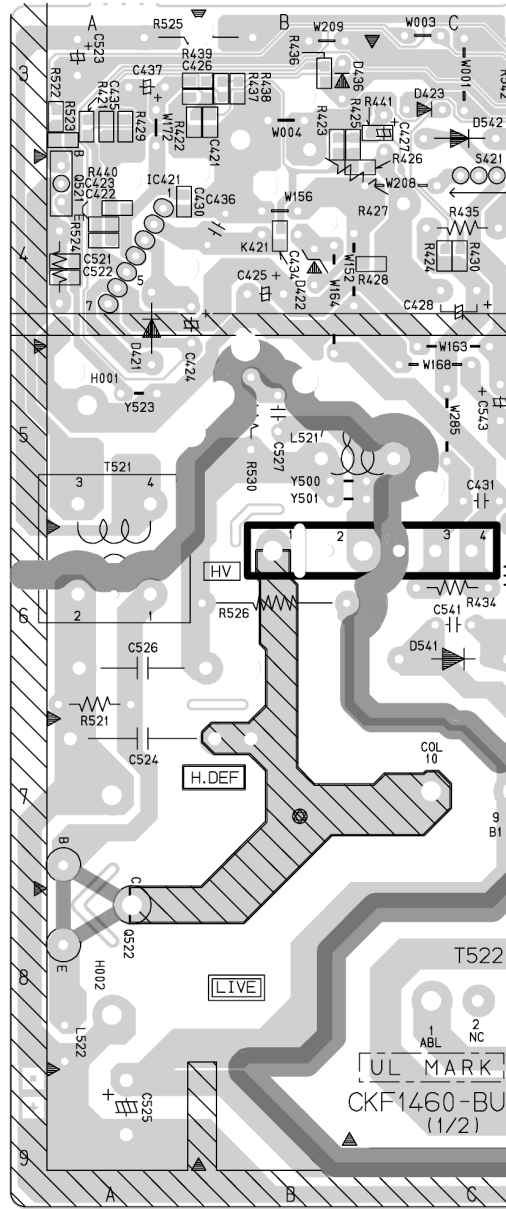
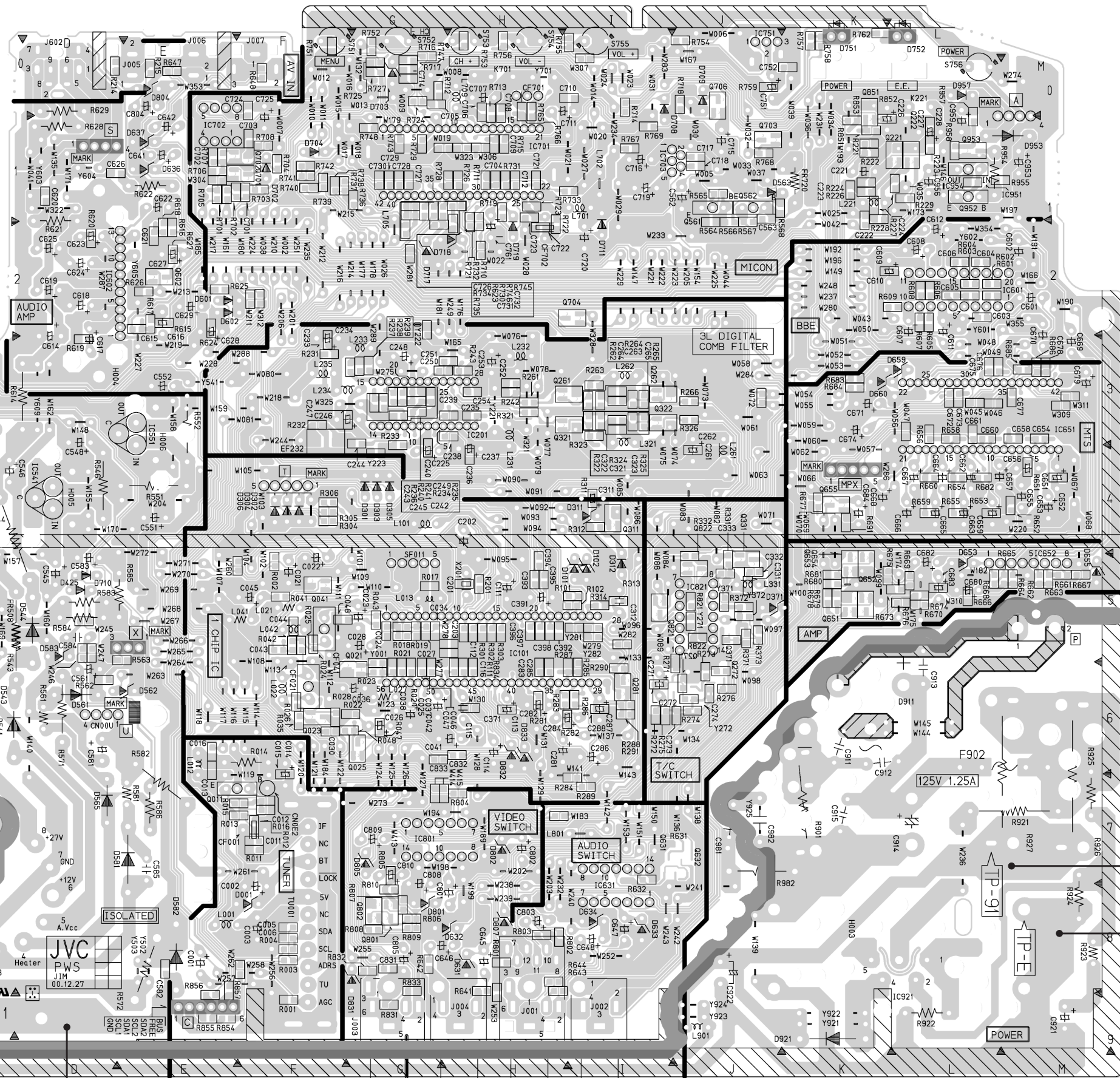
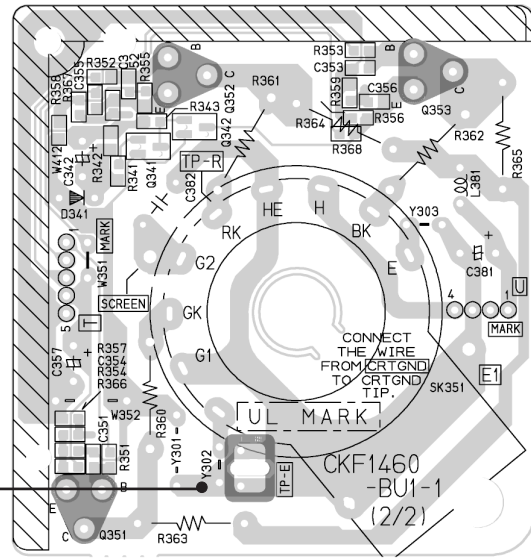

(T)

TP-91 (B1)

TPE (T)

■ CHANNEL CHART (US)

MODE		BAND	CHANNEL		TUNER BAND			
TV	CATV		REAL	DISP.				
○	○	VL	02		I			
			03					
			04					
			05					
			06					
			07					
	○	VH	08		II			
			09					
			10					
			11					
			12					
			13					
			x	○		MID	A	14
B	15							
C	16							
D	17							
E	18							
F	19							
G	20							
H	21							
I	22							
○	SUPER	J			23		II	
		K			24			
		L			25			
		M		26				
		N		27				
		O		28				
		P		29				
		Q		30				
		R		31				
		S		32				
		T		33				
		U		34				
		V		35				
		W		36				
○	○	HYPER		W+1	37	IV		
				W+2	38			
				W+3	39			
				W+4	40			
				W+5	41			
				W+6	42			
				W+7	43			
				W+8	44			
				W+9	45			
				W+10	46			
				W+11	47			
				W+12	48			
				W+13	49			
			W+14	50				
			W+15	51				
			W+16	52				
			W+17	53				
			W+18	54				
W+19	55							
W+20	56							
W+21	57							
W+22	58							
W+23	59							
W+24	60							
W+25	61							
W+26	62							
W+27	63							
W+28	64							
○	○	ULTRA	W+29	65	IV			
			W+30	66				
			W+31	67				
			W+32	68				
			W+33	69				
			W+34	70				

■ CHANNEL CHART (CA)

MODE		BAND	CHANNEL		TUNER BAND				
TV	CATV		REAL	DISP.					
x	○	ULTRA	W+35	71	IV				
			W+36	72					
			W+37	73					
			W+38	74					
			W+39	75					
			W+40	76					
			W+41	77					
			W+42	78					
			W+43	79					
			W+44	80					
			W+45	81					
			W+46	82					
			W+47	83					
			W+48	84					
			W+49	85					
			W+50	86					
			W+51	87					
			W+52	88					
			W+53	89					
			W+54	90					
			W+55	91					
			W+56	92					
			W+57	93					
			W+58	94					
			W+59	100					
			W+60	101					
			W+61	102					
			W+62	103					
			W+63	104					
			W+64	105					
			W+65	106					
			W+66	107					
			W+67	108					
			W+68	109					
			W+69	110					
			W+70	111					
			W+71	112					
			W+72	113					
			W+73	114					
			W+74	115					
			W+75	116					
			W+76	117					
			W+77	118					
			W+78	119					
			W+79	120					
			W+80	121					
			W+81	122					
			W+82	123					
			W+83	124					
			W+84	125					
			○	x		SUB MID	A-8	01	I
							A-4	96	
							A-3	97	
							A-2	98	
							A-1	99	
			○	x		UHF	14 }	69	IV
			TOTAL 180CH { VHF 124CH UHF 56CH						
			NOTE: TO RECEIVE THE SUBSCRIPTION OR PREMIUM PROGRAMMING FROM CERTAIN CABLE COMPANIES. SPECIAL ADAPTERS MAY BE REQUIRED.						

■ CHANNEL CHART (CA)

MODE		BAND	CHANNEL		TUNER BAND				
TV	CATV		REAL	DISP.					
○	○	VL	02		I				
			03						
			04						
			05						
			06						
			07						
	○	VH	08		II				
			09						
			10						
			11						
			12						
			13						
			x	○		MID	A	14	II
B	15								
C	16								
D	17								
E	18								
F	19								
G	20								
H	21								
I	22								
○	SUPER	J			23		III		
		K			24				
		L			25				
		M		26					
		N		27					
		O		28					
		P		29					
		Q		30					
		R		31					
		S		32					
		T		33					
		U		34					
		V		35					
		W		36					
		○		○	HYPER	W+1		37	III
						W+2		38	
W+3	39								
W+4	40								
W+5	41								
W+6	42								
W+7	43								
W+8	44								
W+9	45								
W+10	46								
W+11	47								
W+12	48								
W+13	49								
W+14	50								
W+15	51								
W+16	52								
W+17	53								
W+18	54								
W+19	55								
W+20	56								
W+21	57								
W+22	58								
W+23	59								
W+24	60								
W+25	61								
W+26	62								
W+27	63								
W+28	64								
○	○	ULTRA	W+29	65	IV				
			W+30	66					
			W+31	67					
			W+32	68					
			W+33	69					
			W+34	70					

■ CHANNEL CHART (US)

MODE		BAND	CHANNEL		TUNER BAND				
TV	CATV		REAL	DISP.					
x	○	ULTRA	W+35	71	IV				
			W+36	72					
			W+37	73					
			W+38	74					
			W+39	75					
			W+40	76					
			W+41	77					
			W+42	78					
			W+43	79					
			W+44	80					
			W+45	81					
			W+46	82					
			W+47	83					
			W+48	84					
			W+49	85					
			W+50	86					
			W+51	87					
			W+52	88					
			W+53	89					
			W+54	90					
			W+55	91					
			W+56	92					
			W+57	93					
			W+58	94					
			W+59	100					
			W+60	101					
			W+61	102					
			W+62	103					
			W+63	104					
			W+64	105					
			W+65	106					
			W+66	107					
			W+67	108					
			W+68	109					
			W+69	110					
			W+70	111					
			W+71	112					
			W+72	113					
			W+73	114					
			W+74	115					
			W+75	116					
			W+76	117					
			W+77	118					
			W+78	119					
			W+79	120					
			W+80	121					
			W+81	122					
			W+82	123					
			W+83	124					
			W+84	125					
			○	x		SUB MID	A-8	01	I
							A-4	96	
							A-3	97	
							A-2	98	
							A-1	99	
			○	x		UHF	14 }	69	IV
			TOTAL 180CH { VHF 124CH UHF 56CH						
			NOTE: TO RECEIVE THE SUBSCRIPTION OR PREMIUM PROGRAMMING FROM CERTAIN CABLE COMPANIES. SPECIAL ADAPTERS MAY BE REQUIRED.						

JVC SERVICE & ENGINEERING COMPANY OF AMERICA

DIVISION OF JVC AMERICAS CORP.

Head office :	1700 Valley Road, Wayne, New Jersey 07470	(973)315-5000
East Coast :	10 New Maple Avenue, Pine Brook, New Jersey 07058	(973)396-1000
Midwest :	705 Enterprise St. Aurora, Illinois 60504	(630)851-7855
West Coast :	5665 Corporate Avenue, Cypress, California 90630	(714)229-8011
Southwest :	10700 Hammerly, Suite 105, Houston, Texas 77043	(713)935-9331
Hawaii :	2969 Mapunapuna Place, Honolulu, Hawaii 96819	(808)833-5828
Southeast :	1500 Lakes Parkway, Lawrenceville, Georgia 30243	(770)339-2582

JVC CANADA INC.

Head office :	21 Finchdene Square Scarborough, Ontario M1X 1A7	(416)293-1311
Vancouver :	13040 Worster Court Richmond B.C. V6V 2B3	(604)270-1311

JVC[®]